



CEC

Chandigarh
Engineering College

Fluid Machinery (BTME-603)

UNIT -3

FRANCIS AND KAPLAN

TURBINE

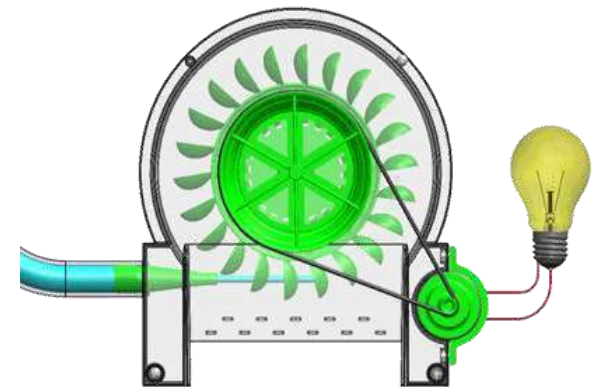

Course Objectives:

CO3: To familiarize the students with the principle and working of Francis and Kaplan turbines to calculate output and their design parameters.

Topics

1. Classification of Turbines
2. Selection of Turbines
3. Design of Turbines - Francis, Kaplan
4. Draft Tube
5. Surge Tanks
6. Governing of Turbines
7. Unit Speed, Unit Discharge, Unit Power
8. Characteristic Curves of Hydraulic Turbines
9. Similitude or Model Analysis
10. Cavitations

Classification of Turbines

1. According to type of energy at Inlet
 - a) Impulse Turbine - Pelton Wheel
Requires High Head and Low Rate of Flow
 - a) Reaction Turbine - Francis, Kaplan
Requires Low Head and High Rate of Flow
2. According to direction of flow through runner
 - a) Tangential Flow Turbine - Pelton Wheel
 - b) Radial Flow Turbine - Francis Turbine
 - c) Axial Flow Turbine - Kaplan Turbine
 - d) Mixed Flow Turbine - Modern Francis Turbine



CEC

Chandigarh
Engineering College

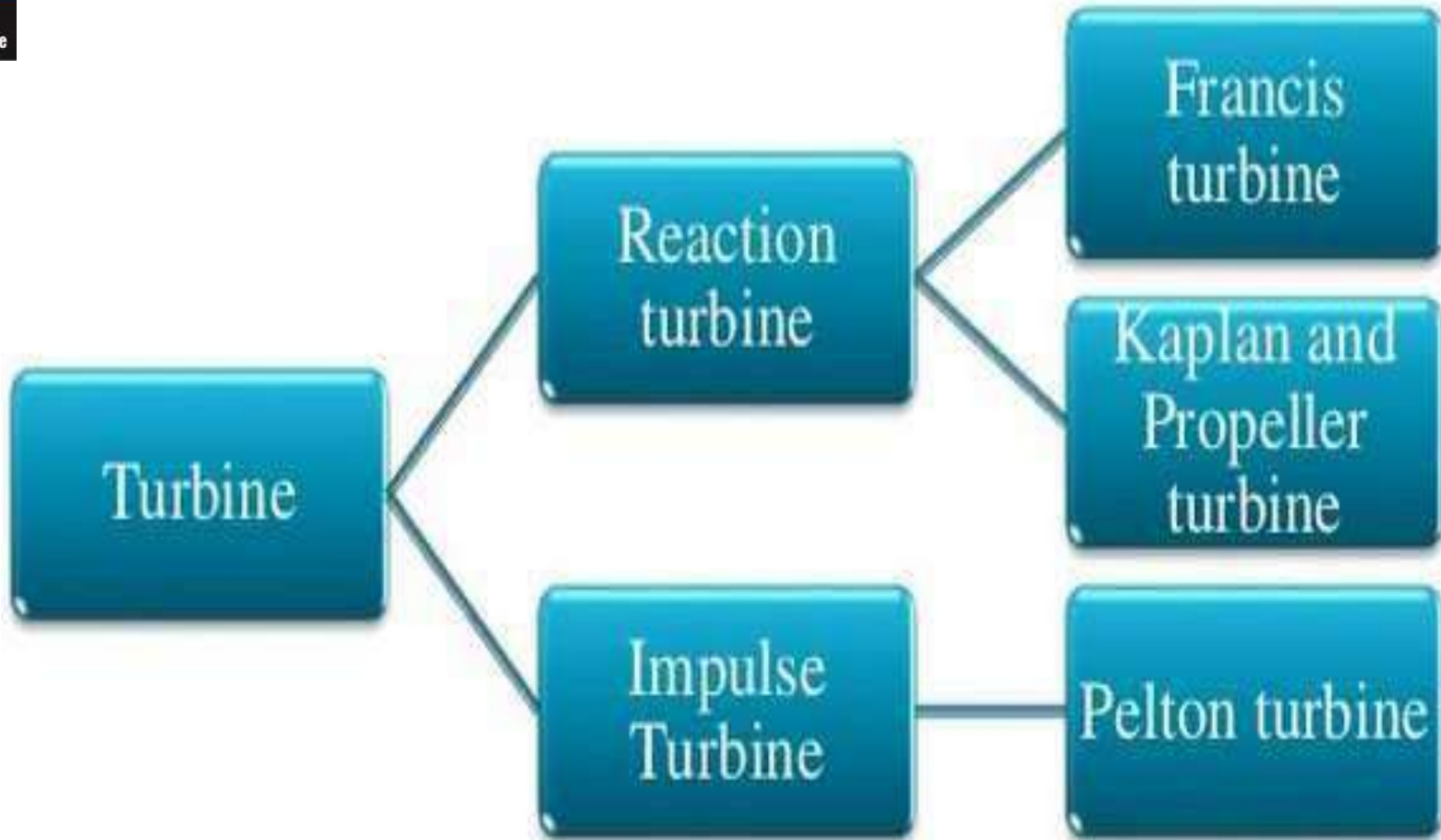



CEC

Chandigarh Engineering College

Impulse Turbine

Reaction Turbine

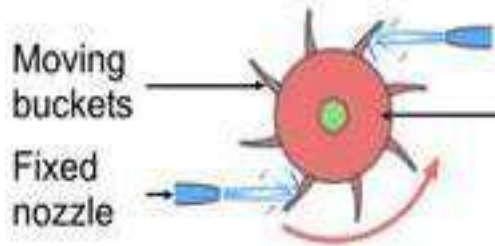

Moving buckets

Fixed nozzle

Rotor

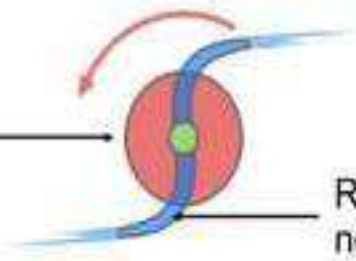

Rotating nozzle

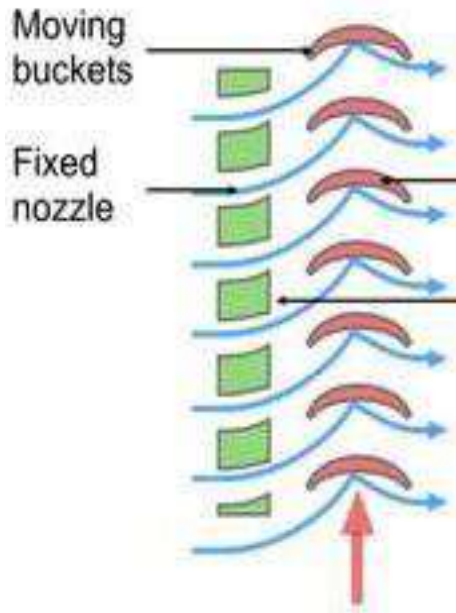

Moving buckets

Fixed nozzle

Rotor

Stator

Rotation

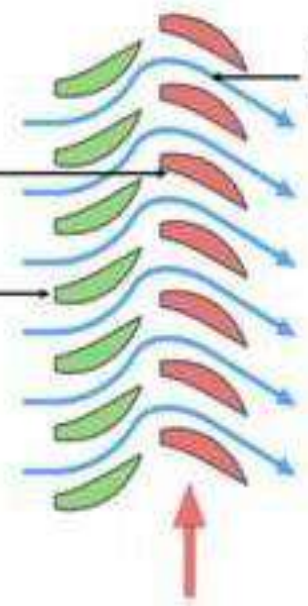

Rotating nozzle

Classification of Turbines

3. According to Head at Inlet of turbine

- a) High Head Turbine - Pelton Wheel
- b) Medium Head Turbine - Francis Turbine
Kaplan Turbine
- c) Low Head Turbine -

4. According to Specific Speed of Turbine

- a) Low Specific Speed Turbine - Pelton Wheel
- b) Medium Specific Speed Turbine - Francis Turbine
- c) High Specific Speed Turbine - Kaplan Turbine

Classification according to Specific Speed of Turbines

Type of turbine	Type of runner	Specific speed
Pelton	Slow	10 to 20
	Normal	20 to 28
	Fast	28 to 35
Francis	Slow	60 to 120
	Normal	120 to 180
	Fast	180 to 300
Kaplan	-	300 to 1000

Classification of Turbines

5. According to Disposition of Turbine Shaft

- a) Horizontal Shaft - Pelton Wheel
- b) Vertical Shaft - Francis & Kaplan Turbines



CEC

Chandigarh
Engineering College

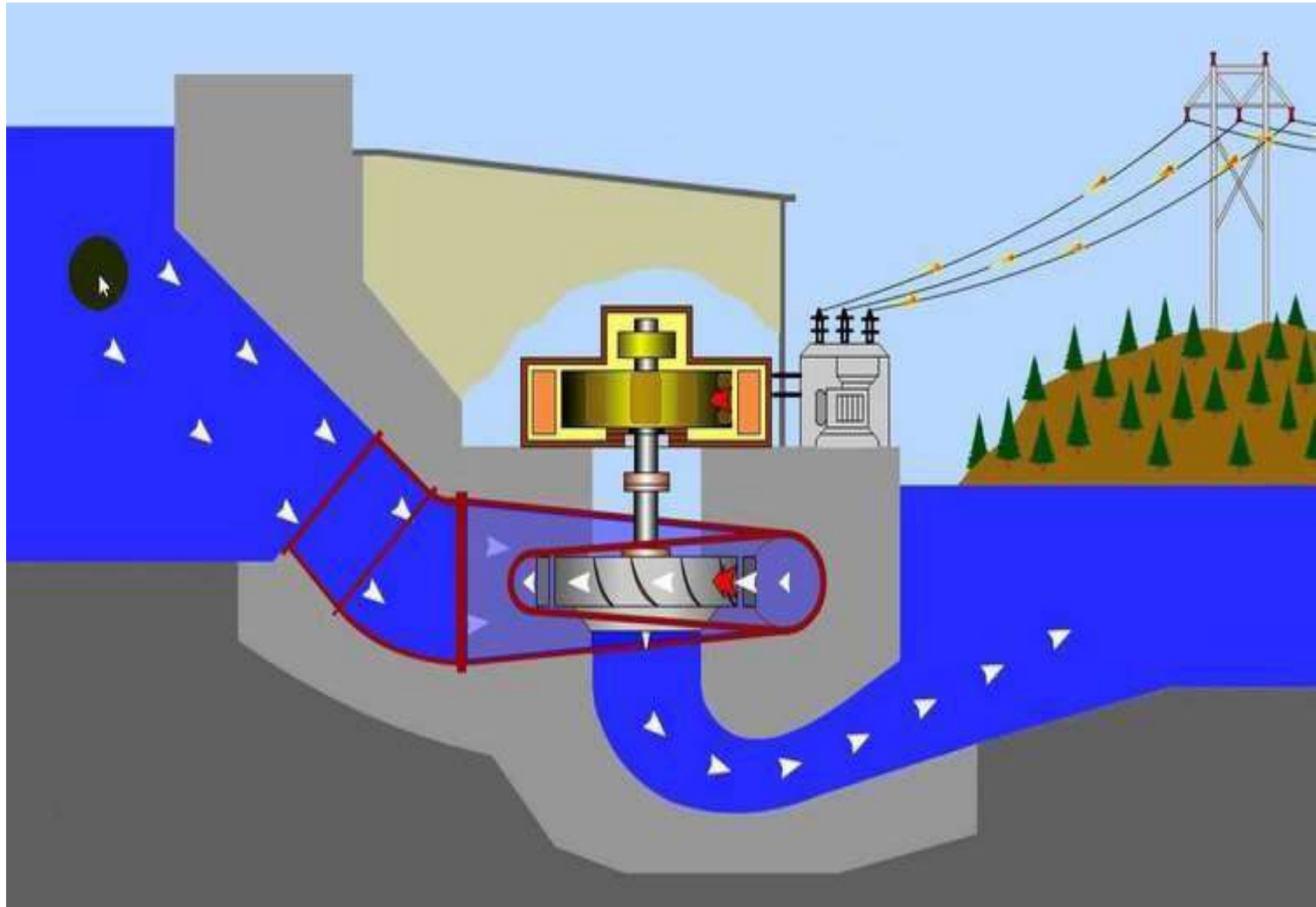

FRANCIS TURBINE



CEC

Chandigarh
Engineering College

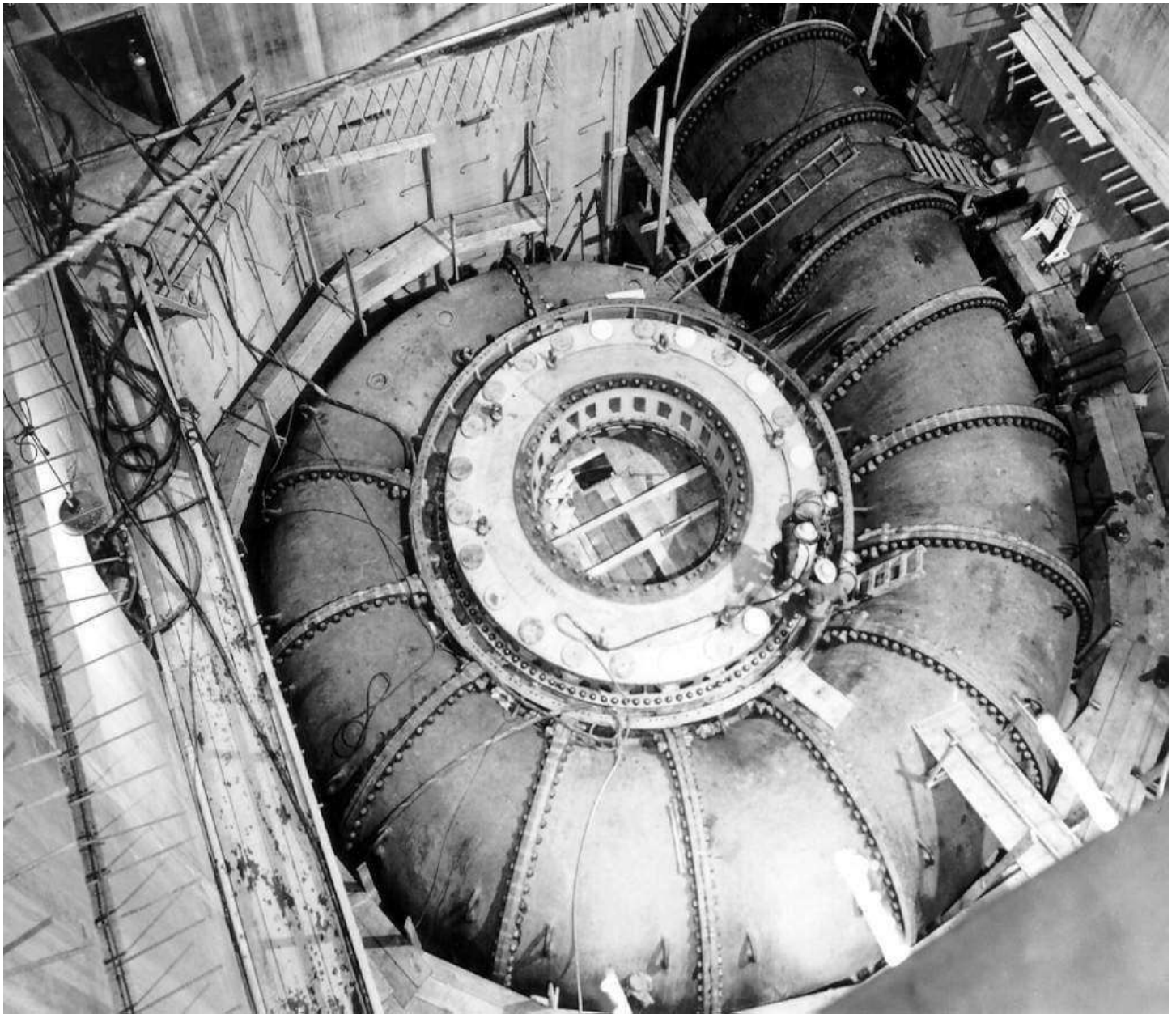

FRANCIS



FRANCIS TURBINE

FRANCIS TURBINE

- The **Francis turbine** is an inward-flow reaction turbine that combines radial and axial flow concepts.
- It was developed by James .B. Francis.



SPECIFICATION

They operate in a water head from 40 to 600 m (130 to 2,000 ft).

- The power generated is 800MW.
- The speed range of the turbine is from 75 to 1000 rpm.
- It give efficiency of about 90%.
- The runner diameters are between 0.91 to 10.6 m.





CEC

Chandigarh
Engineering College

THE MAIN PARTS ARE :-

- 1 **Spiral casing**
- 2 **Guide vanes**
- 3 **Runners**
- 4 **Draft tube**

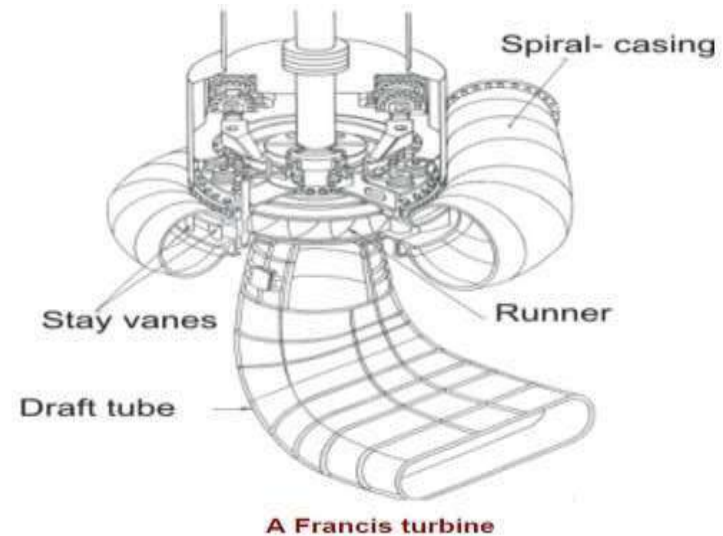

1] **Spiral casing** :- It guides the water to the guide vanes and also control the flow.

2] **Guide vanes** :- They guide the water to runner and get closed on increase in flow.time



CEC

Chandigarh
Engineering College

3Runner :- They are heart of the turbine and rotate on the impact of flow.

4Draft tube :- It is place from where the water is discharged from the turbine

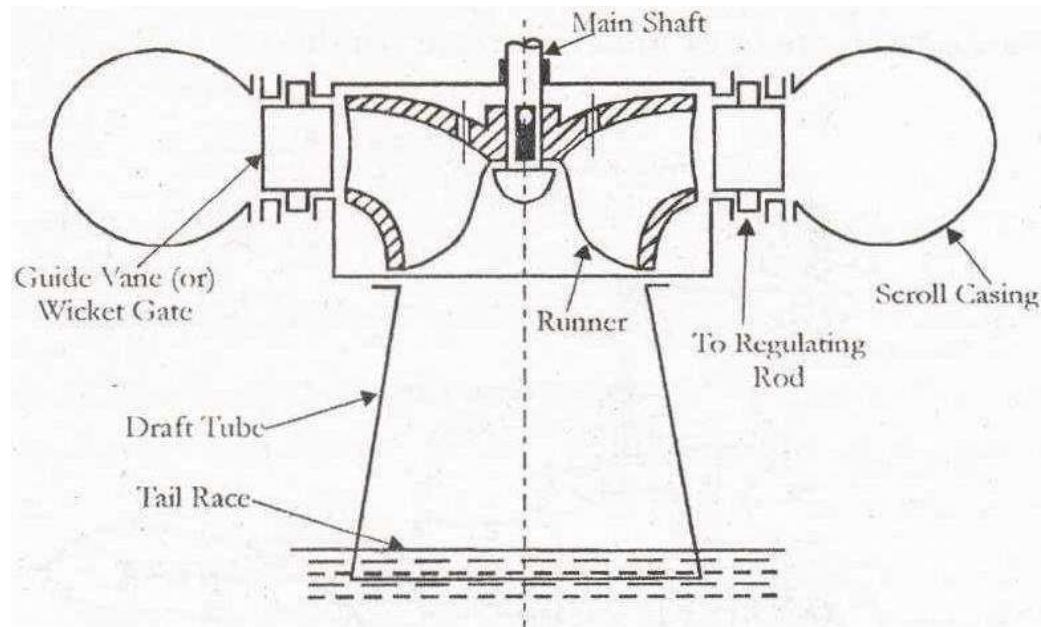

WORKING

Penstock conveys water from the upstream to the turbine runner. Spiral Casing constitutes a closed passage whose cross-sectional area gradually decreases along the flow direction; area is maximum at inlet and nearly zero at exit.

- The vanes direct the water on to the runner at an angle appropriate to the design, the motion of them is given by means of hand wheel.
- Runner Blades move due to the driving force on the runner which is due to impulse and reaction effect.
- Draft Tube is gradually expanding tube which discharges water, passing through the runner to the tail race.





CEC

Chandigarh
Engineering College



www.LearnEngineering.org



CEC

Chandigarh
Engineering College

Design of Francis Turbine

Guidelines:

1. Velocity of Wheel,

$$u = u_1 = u_2 = \frac{\pi DN}{60}$$

2. Work done per second or Power,

$$3. = \rho a V_1 [V_{w_1} u_1 \pm V_{w_2} u_2] = \rho Q [V_{w_1} u_1 \pm V_{w_2} u_2]$$

4. Discharge,

$$u_1 = \frac{\pi D_1 \times N}{60}, \quad u_2 = \frac{\pi D_2 \times N}{60}$$

$$Q = \pi D_1 B_1 V_{f_1} = \pi D_2 B_2 V_{f_2}$$

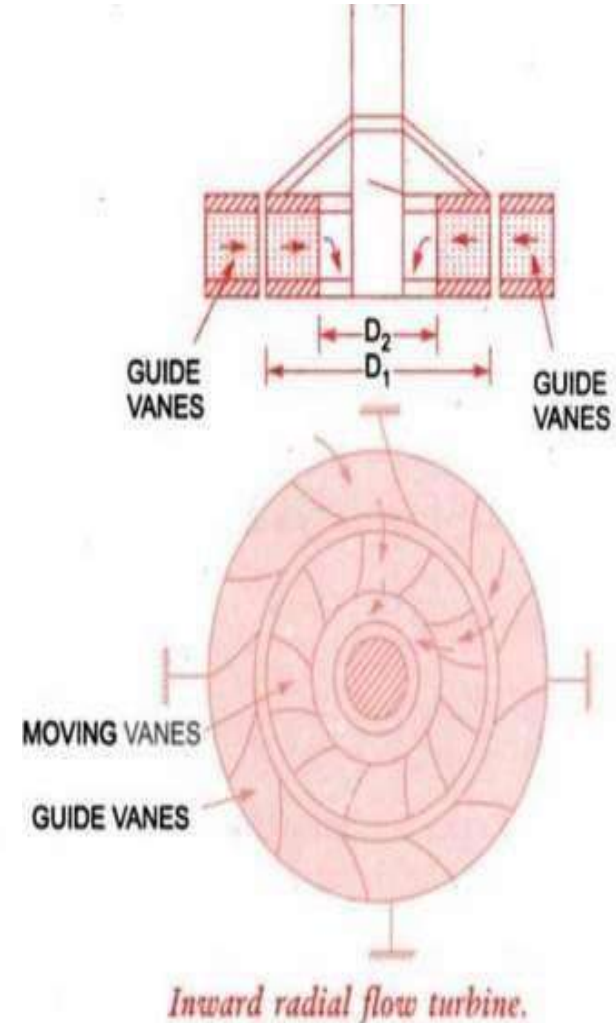

Design of Francis Turbine

Problems:

1. A reaction turbine works at 450 rpm under a head of 120 m. Its diameter at inlet is 1.2 m and the flow area is 0.4 m^2 . The angle made by the absolute and relative velocities at inlet are 20° and 60° respectively with the tangential velocity. Determine
 - (i) the discharge through the turbine
 - (ii) power developed
 - (iii) efficiency.Assume radial discharge at outlet.
2. A Francis turbine has inlet wheel diameter of 2 m and outlet diameter of 1.2 m. The runner runs at 250 rpm and water flows at 8 cumecs. The blades have a constant width of 200 mm. If the vanes are radial at inlet and the discharge is radially outwards at exit, make calculations for the angle of guide vane at inlet and blade angle at outlet



CEC

Chandigarh
Engineering College

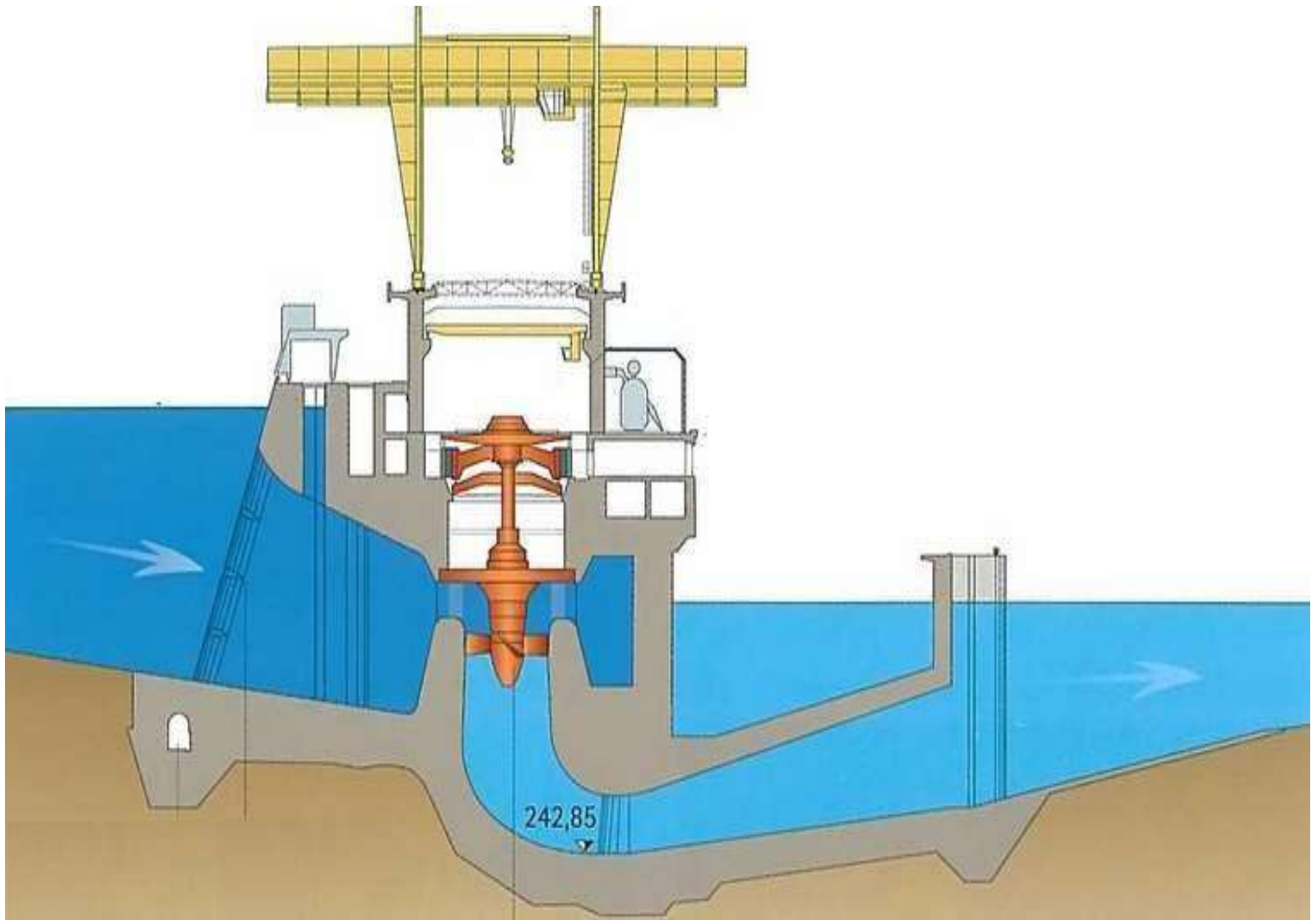

KAPLAN TURBINE



CEC

Chandigarh
Engineering College

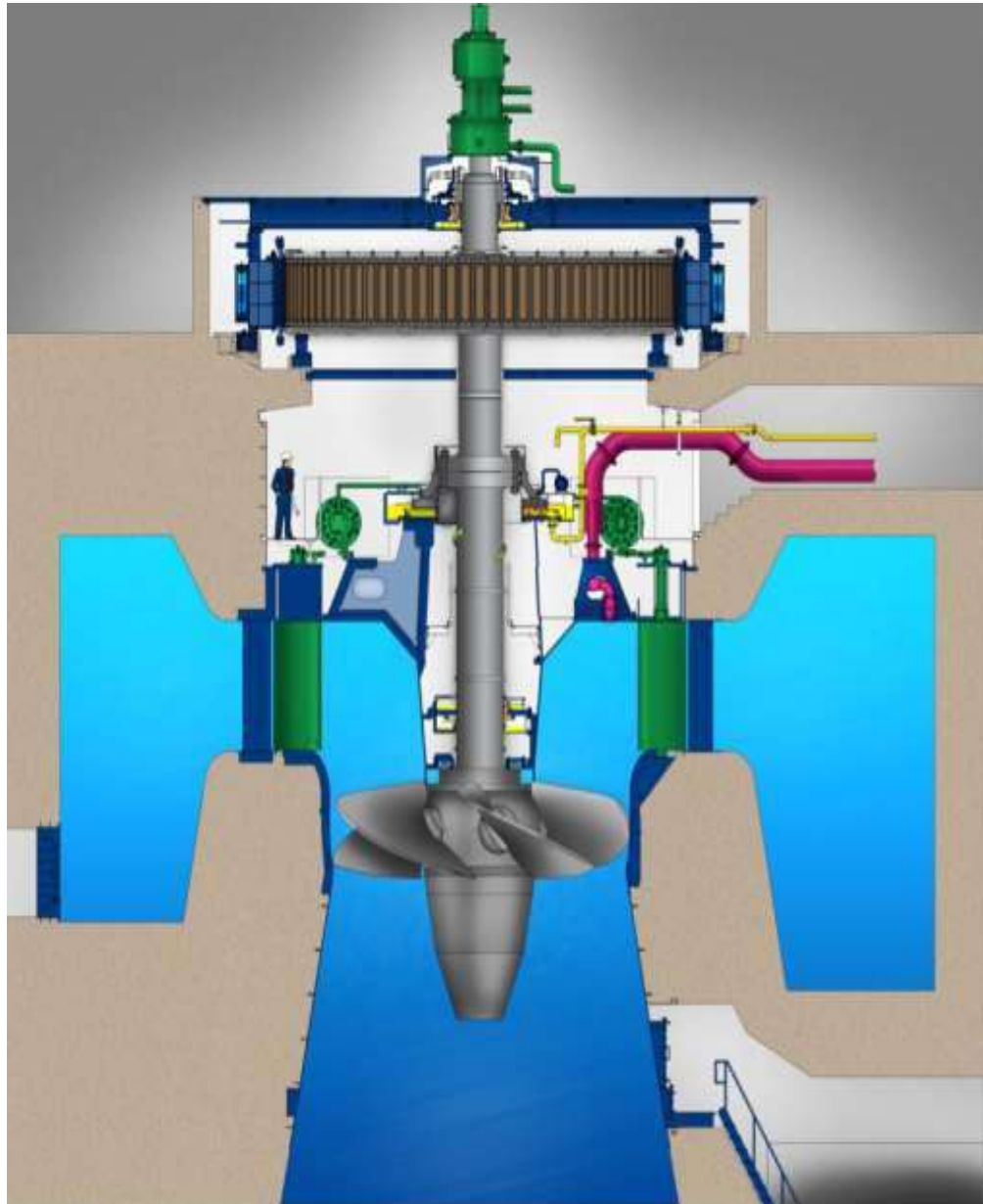

**KAPLAN
TURBINE**



CEC

Chandigarh
Engineering College



**FRANCIS
TURBINE**

KAPLAN TURBINE

The **Kaplan turbine** is a propeller-type water turbine which has adjustable blades. It was developed in 1913 by Austrian professor Viktor Kaplan.

- It is mainly used for **low-head** applications.



SPECIFICATIONS

- The head ranges from 10–70 metres
- The output varies from 5 to 200 MW.
 - Runner diameters are between 2 and 11 metres.
 - The rotational speed rate ranges from 69.2 rpm to 429 rpm
 - It gives highest efficiency which is over 90%.

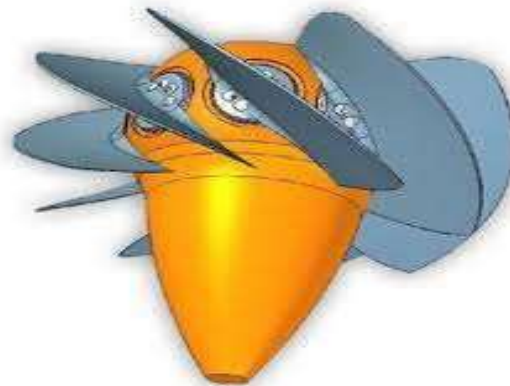



CEC

Chandigarh
Engineering College

THE MAIN COMPONENTS ARE :-

- 1 Scroll casing
- 2 Guide vanes
- 3 Draft tube
- 4 Runner
- 5 Hub

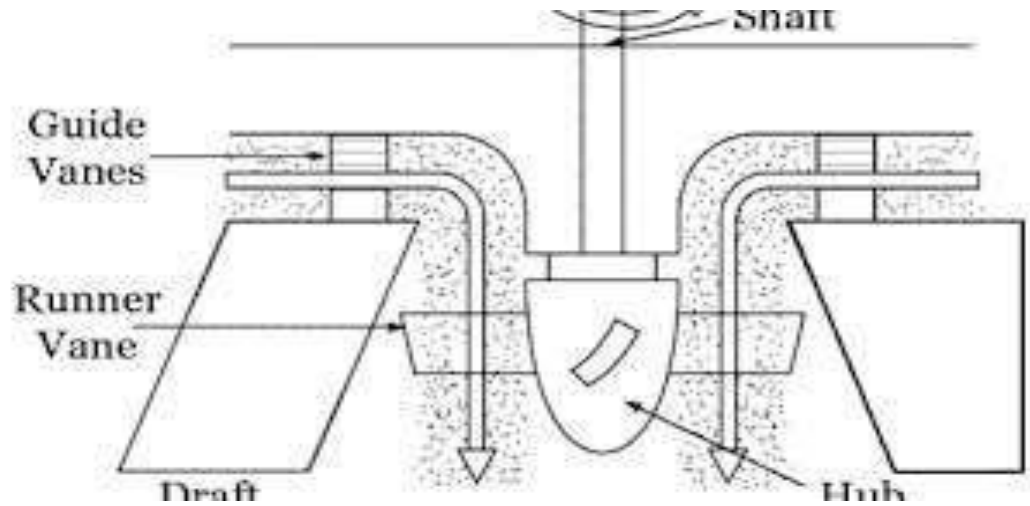

1) **Scroll casing**: It is the casing which guides the water and control the water passage.

2) **Guide vanes** : It is the vanes which guide the water and perform same function that by scroll.

3 **Draft tube**:- It discharges the water to trail race through gradually expanding tube.

4 **Runner** :- It is connected to shaft of the generator.

5 **Hub**:- It part on which runner is mounted

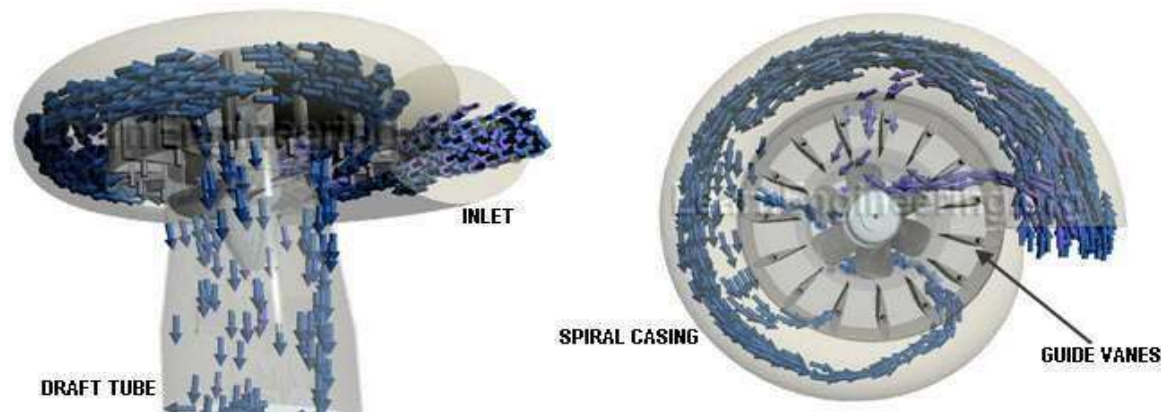



CEC

Chandigarh
Engineering College

WORKING

The water from the penstocks enters the scroll casing and then moves to the guide vanes.

- From the guide vanes, the water turns through 90° and flows axially through the runner.
- For Kaplan Turbine, the shaft of the turbine is vertical. The lower end of the shaft is made larger and is called 'Hub' or 'Boss'.
- The vanes are fixed on the hub and hence Hub acts as runner for axial flow turbine.

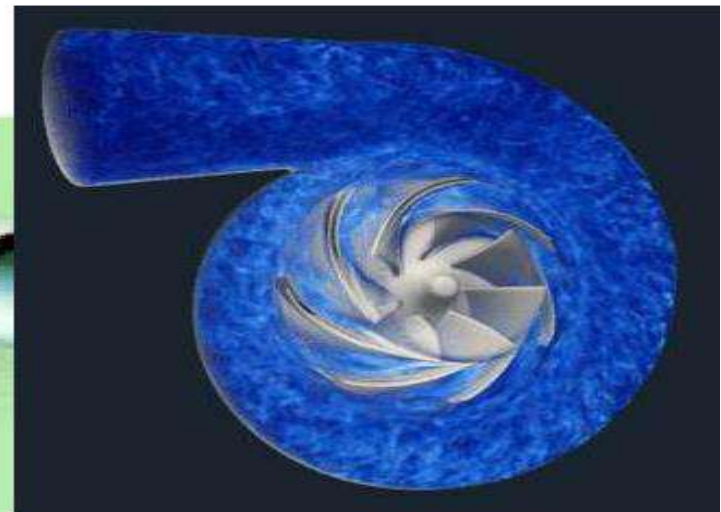



KAPLAN TURBINE

Chandigarh
Engineering College



www.LearnEngineering.org

APLLICATIONS

- The kaplan turbine is used in Indian.

SR NO.	STATION	POWER GENERATE D [MW]
1.	LPH	55
2.	KADRA	150
3.	KODASSALLI	120
4.	ALMATTI	275

Design of Kaplan Turbine

Guidelines:

1. Velocity of Wheel, $u_1 = u_2 = \frac{\pi D_m \times N}{60}$ where Mean diameter, $D_m = \frac{D_o + D_b}{2}$

2. Work done per second =

$$\rho a V_1 [V_{w_1} + V_{w_2}] \times u = \rho Q [V_{w_1} + V_{w_2}] \times u$$

3. Velocity of Flow at Inlet and Outlet are equal $V_{f_1} = V_{f_2}$

4. Discharge, $Q = \frac{\pi}{4} (D_o^2 - D_b^2) \times V_{f_1}$

5. Flow Ratio = $\frac{V_{f_1}}{\sqrt{2gH}}$



CEC

Chandigarh
Engineering College

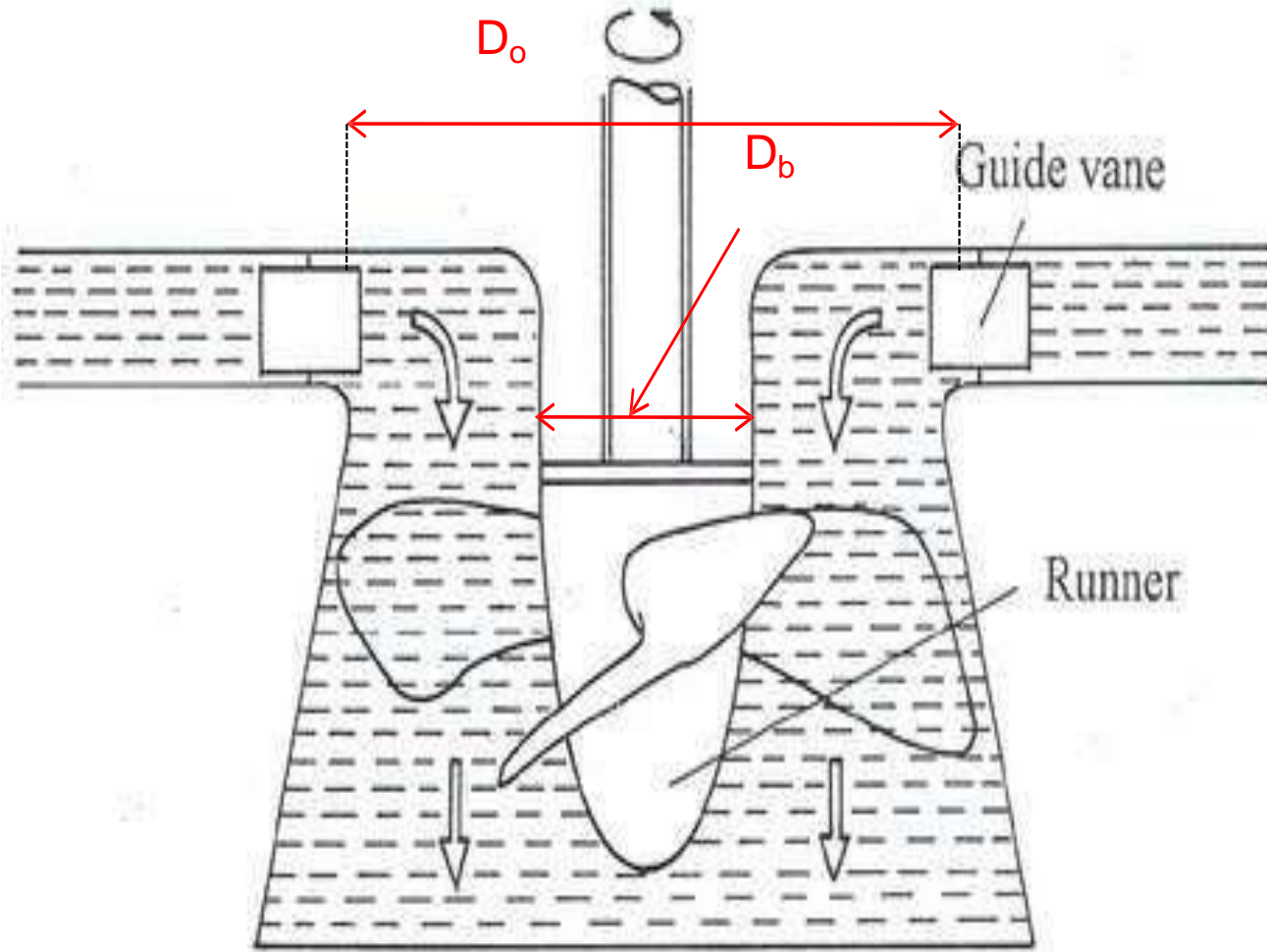

Kaplan Turbine

$$Q = \frac{\pi}{4} (D_o^2 - D_b^2) \times V_{f1}$$

Design of Kaplan Turbine

Problems:

1. A Kaplan turbine develops 9000 kW under a net head of 7.5 m. Overall efficiency of the wheel is 86% The speed ratio based on outer diameter is 2.2 and the flow ratio is 0.66. Diameter of the boss is 0.35 times the external diameter of the wheel. Determine the diameter of the runner and the specific speed of the runner.
2. A Kaplan turbine working under a head of 25 m develops 16,000 kW shaft power. The outer diameter of the runner is 4 m and hub diameter is 2 m. The guide blade angle is 35° . The hydraulic and overall efficiency are 90% and 85% respectively. If the velocity of whirl is zero at outlet, determine runner vane angles at inlet and outlet and speed of turbine.

Selection of Turbine

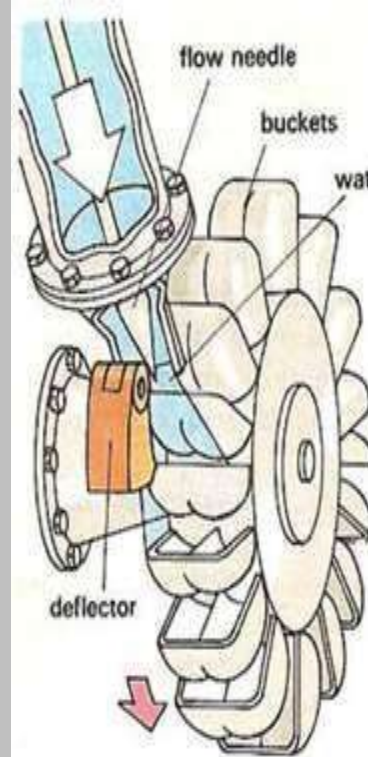
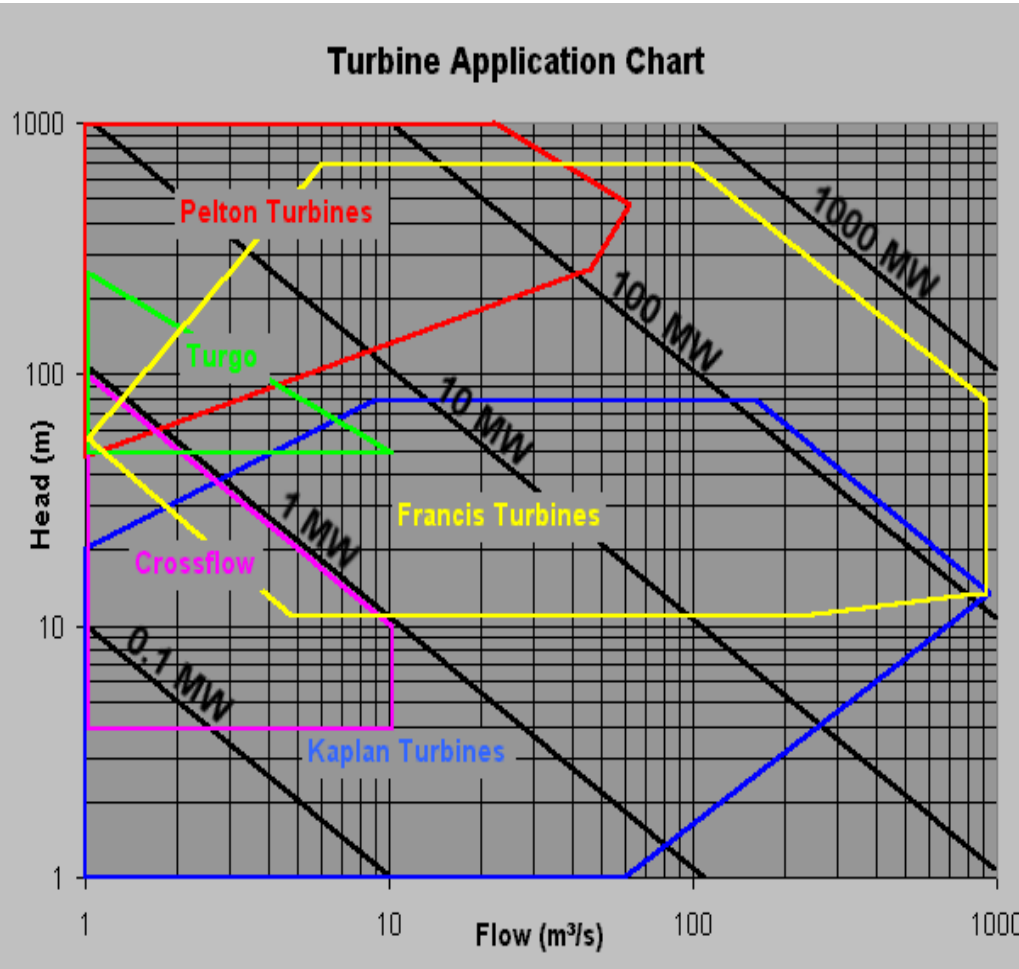

Pelton

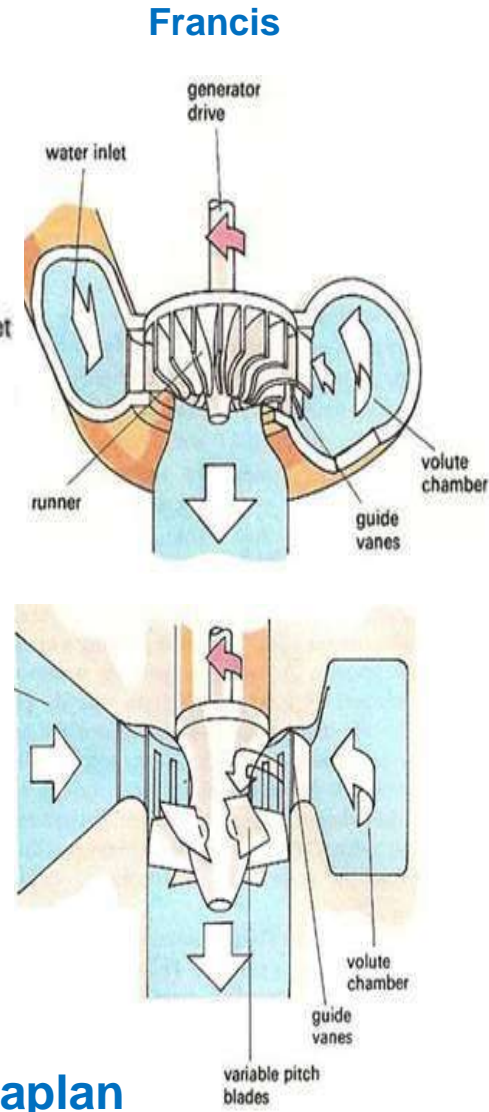

Kaplan

Draft Tube

The water after working on the turbine, imparts its energy to the vanes and runner, thereby reducing its pressure less than that of atmospheric pressure. As the water flows from higher pressure to lower pressure, it cannot come out of the turbine and hence a divergent tube is connected to the end of the turbine.

Draft tube is a divergent tube one end of which is connected to the outlet of the turbine and other end is immersed well below the tailrace (water level).

The major function of the draft tube is to increase the pressure from the inlet to outlet of the draft tube as it flows through it and hence increase it more than atmospheric pressure. The other function is to safely discharge the water that has worked on the turbine to tailrace.



CEC

Chandigarh
Engineering College

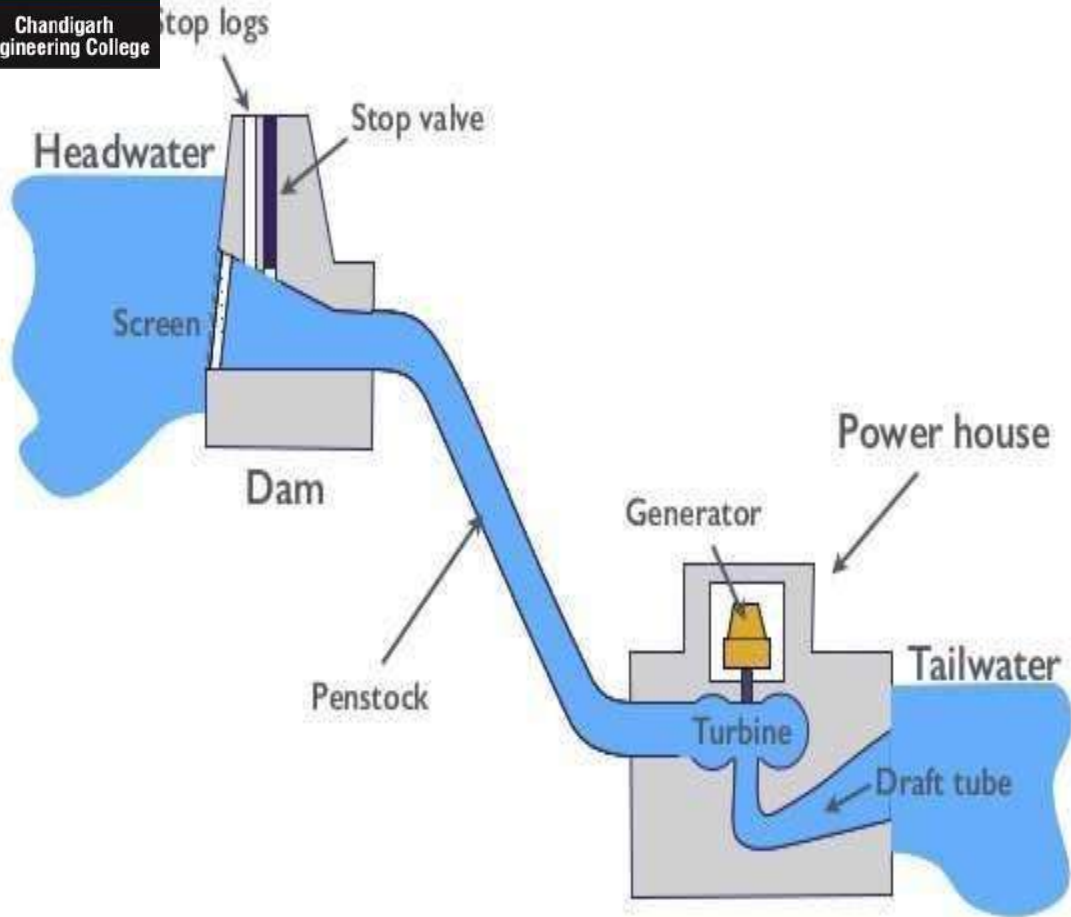

Draft Tube

Types of Draft Tube

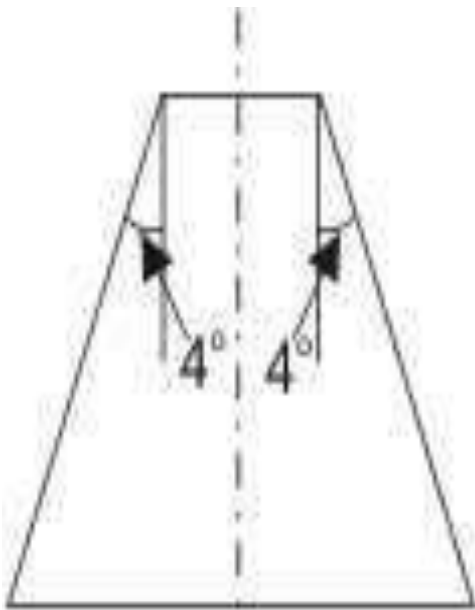

(a) Straight type

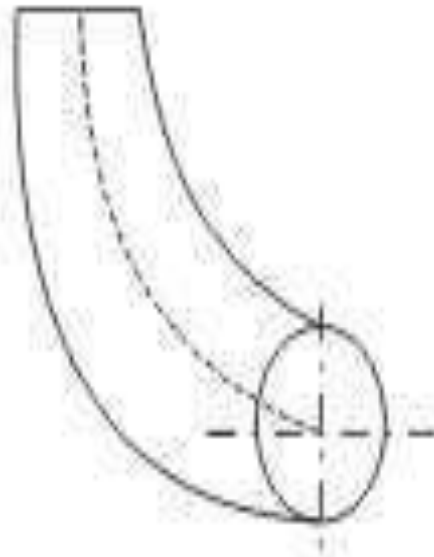

(b) Simple elbow type

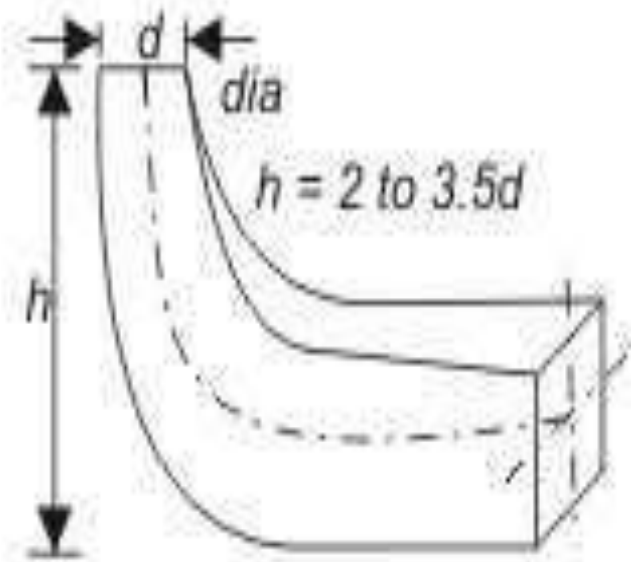

(c) Elbow type with
varying cross-section

Surge Tanks

Surge tank (or surge chamber) is a device introduced within a hydropower water conveyance system having a rather long pressure conduit to absorb the excess pressure rise in case of a sudden valve closure. The surge tank is located between the almost horizontal or slightly inclined conduit and steeply sloping penstock and is designed as a chamber excavated in the mountain.

It also acts as a small storage from which water may be supplied in case of a sudden valve opening of the turbine.

In case of a sudden opening of turbine valve, there are chances of penstock collapse due to a negative pressure generation, if there is no surge tank.



CEC

Chandigarh
Engineering College

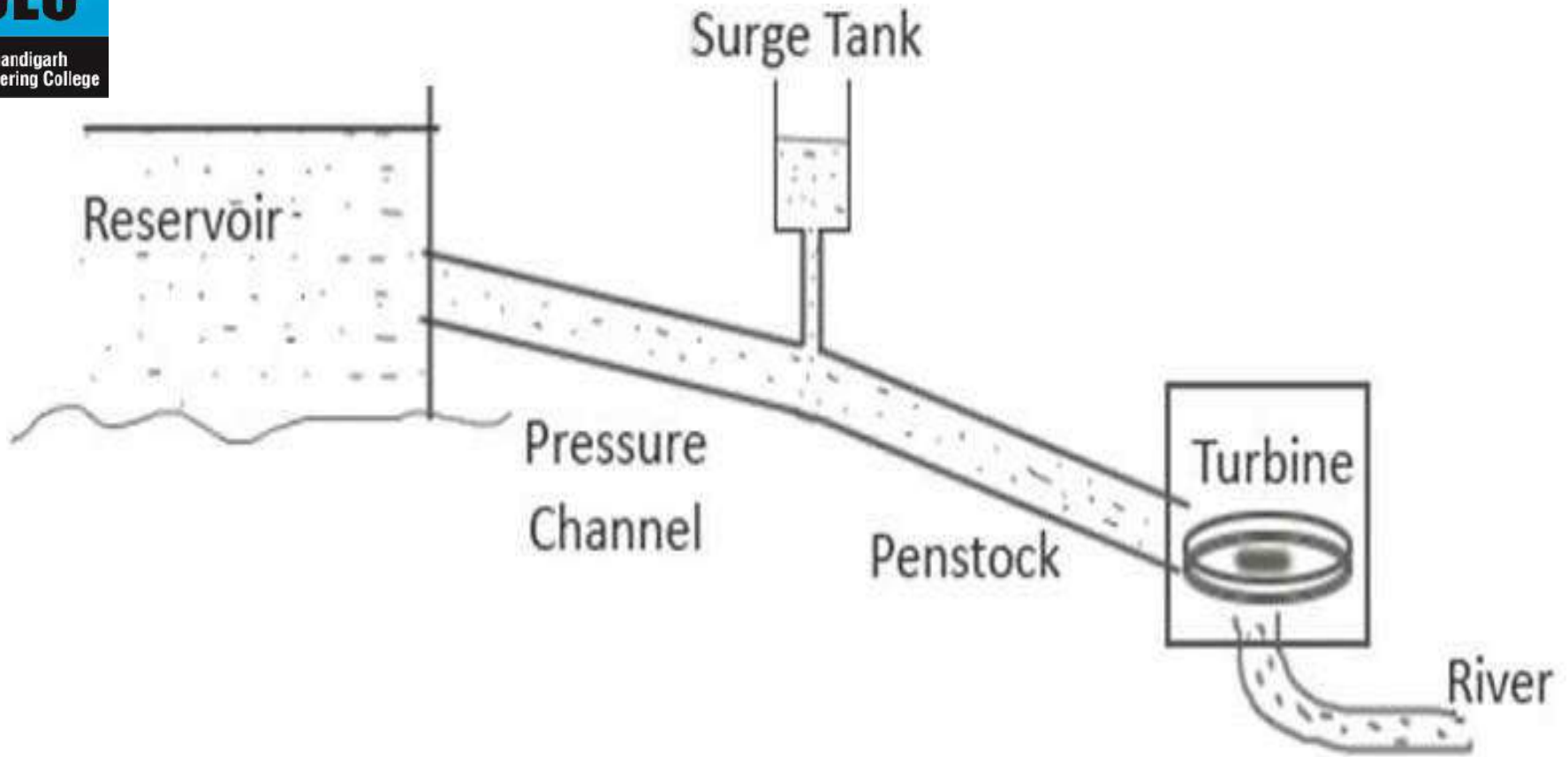

Surge Tank

Governing of Turbines

Governing means Speed Regulation.

Governing system or governor is the main controller of the hydraulic turbine. The governor varies the water flow through the turbine to control its speed or power output.

1. Impulse Turbine

- a) Spear Regulation
- b) Deflector Regulation
- c) Combined

2. Reaction Turbine



CEC

Chandigarh
Engineering College

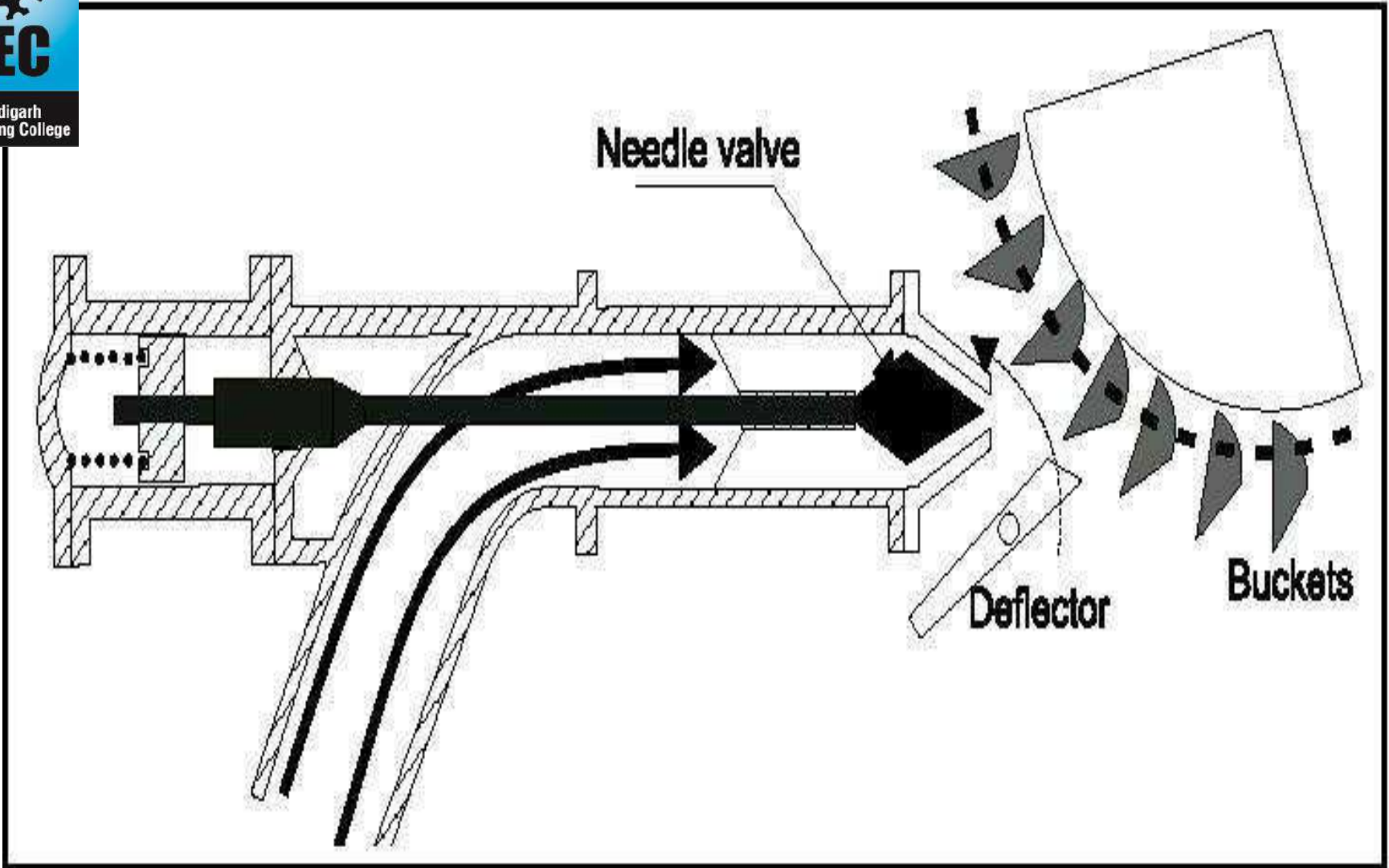

Governor of Pelton Wheel

Performance of Turbines under unit quantities

The unit quantities give the speed, discharge and power for a particular turbine under a head of 1m assuming the same efficiency. Unit quantities are used to predict the performance of turbine.

1. Unit speed (N_u) - Speed of the turbine, working under unit head
$$N_u = \frac{N}{\sqrt{H}}$$

2. Unit power (P_u) - Power developed by a turbine, working under a unit head
$$P_u = \frac{P}{H^{3/2}}$$

3. Unit discharge (Q_u) - The discharge of the turbine working under a unit head
$$Q_u = \frac{Q}{\sqrt{H}}$$



Unit Speed, Unit discharge and Unit Power is definite characteristics of a turbine.

If for a given turbine under heads H_1, H_2, H_3, \dots the corresponding speeds are N_1, N_2, N_3, \dots , the corresponding discharges are Q_1, Q_2, Q_3, \dots and the powers developed are P_1, P_2, P_3, \dots . Then

$$\text{Unit speed} = N_u = \frac{N_1}{\sqrt{H_1}} = \frac{N_2}{\sqrt{H_2}} = \frac{N_3}{\sqrt{H_3}}$$

$$\text{Unit Discharge} = Q_u = \frac{Q_1}{\sqrt{H_1}} = \frac{Q_2}{\sqrt{H_2}} = \frac{Q_3}{\sqrt{H_3}}$$

$$\text{Unit Power} = P_u = \frac{P_1}{H\sqrt{H_1}} = \frac{P_2}{H\sqrt{H_2}} = \frac{P_3}{H\sqrt{H_3}} \text{ or } P_u = \frac{P_1}{H_1^{3/2}} = \frac{P_2}{H_2^{3/2}} = \frac{P_3}{H_3^{3/2}}$$

Thus if speed, discharge and power developed by a turbine under a certain head are known, the corresponding quantities for any other head can be determined.

Specific Speed of Turbine

Specific Speed of a Turbine (N_s)

The specific speed of a turbine is the speed at which the turbine will run when developing unit power under a unit head. This is the type characteristics of a turbine. For a set of geometrically similar turbines the specific speed will have the same value.

$$N_s = \frac{N\sqrt{P}}{H^{5/4}}$$

Unit Quantities & Specific Speed

Problems:

1. Suggest a suitable type of turbine to develop 7000 kW power under a head of 20m while operating at 220 rpm. What are the considerations for your suggestion.
2. A turbine is to operate under a head of 25m at 200 rpm. The discharge is 9 m³/s. If the efficiency is 90%, determine:
 - i) Power generated
 - ii) Speed and Power at a head of 20m

Characteristics Curves of Turbine

These are curves which are characteristic of a particular turbine which helps in studying the performance of the turbine under various conditions. These curves pertaining to any turbine are supplied by its manufacturers based on actual tests.

The characteristic curves obtained are the following:

- a) Constant head curves or main characteristic curves
- b) Constant speed curves or operating characteristic curves
- c) Constant efficiency curves or Muschel curves

Constant head curves or main characteristic curves

Constant head curves:

Maintaining a constant head, the speed of the turbine is varied by admitting different rates of flow by adjusting the percentage of gate opening. The power P developed is measured mechanically. From each test the unit power P_u , the unit speed N_u , the unit discharge Q_u and the overall efficiency are determined.

The characteristic curves drawn are

- a) Unit discharge vs unit speed
- b) Unit power vs unit speed
- c) Overall efficiency vs unit speed

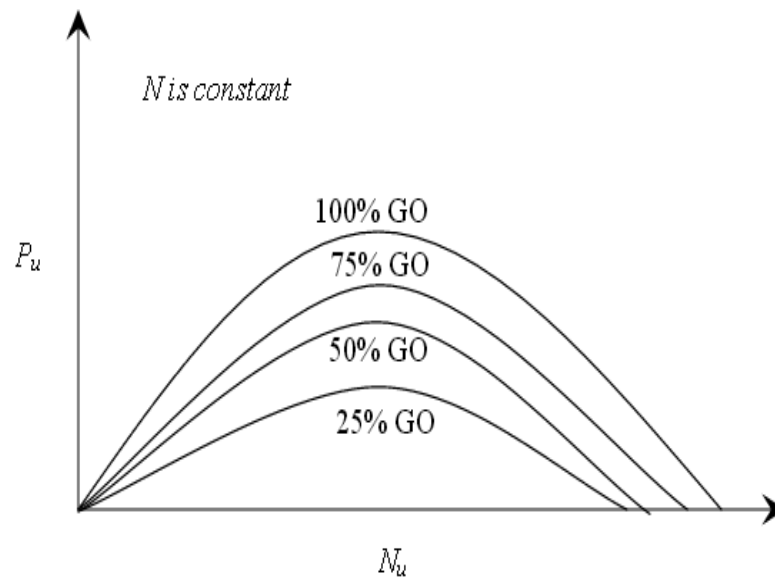
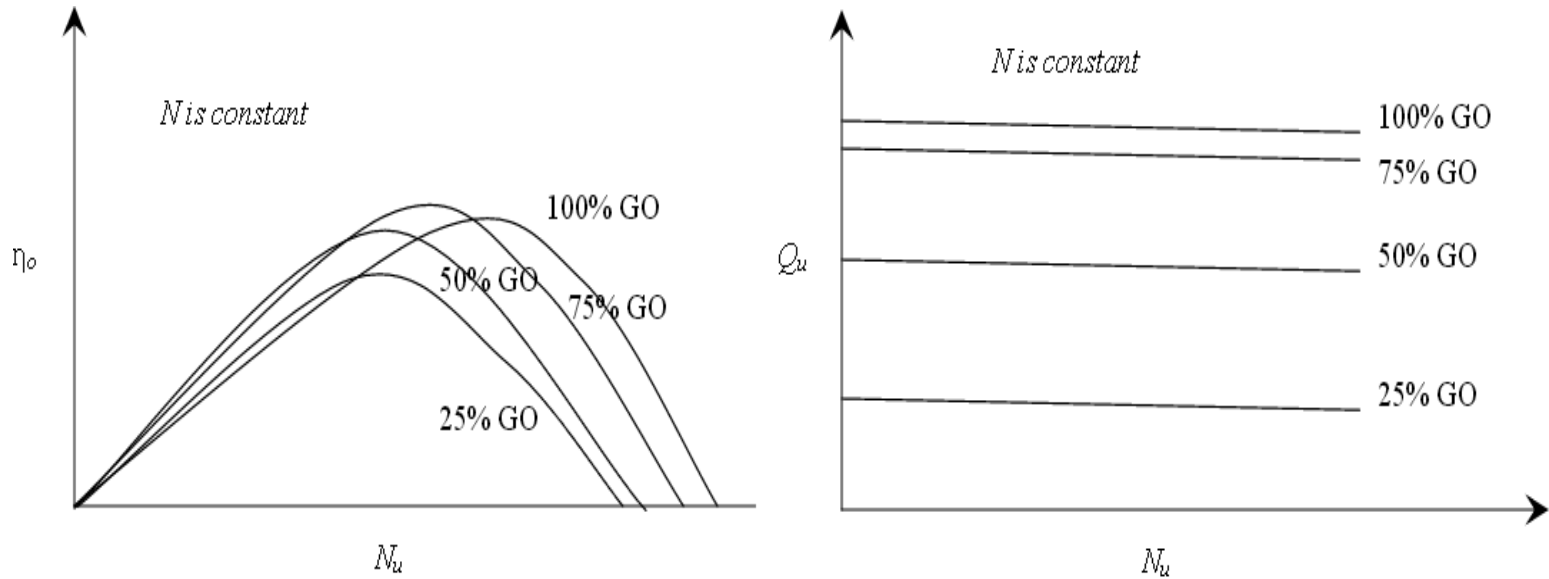

Main Characteristic curves of a Pelton turbine

Constant speed curves or operating characteristic curves

Constant speed curves:

In this case tests are conducted at a constant speed varying the head H and suitably adjusting the discharge Q . The power developed P is measured mechanically. The overall efficiency is aimed at its maximum value.

The curves drawn are

P VS Q

η_o VS Q

η_o VS P_u

$\eta_{o \max}$ VS % Full load

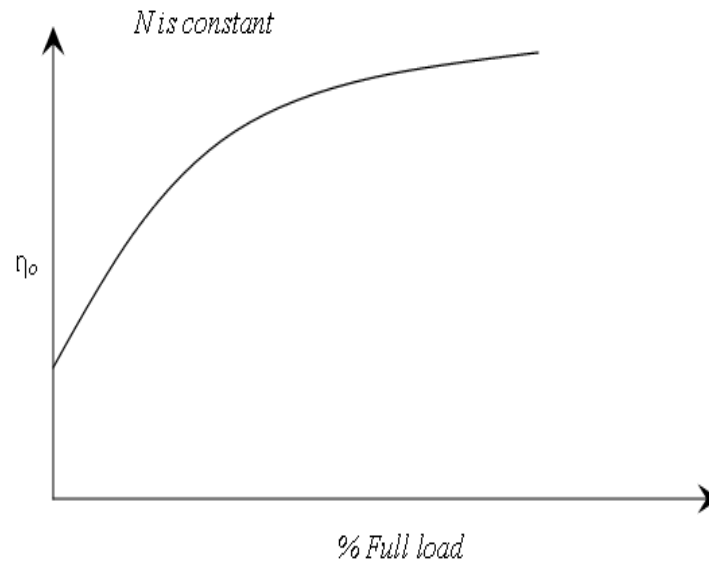
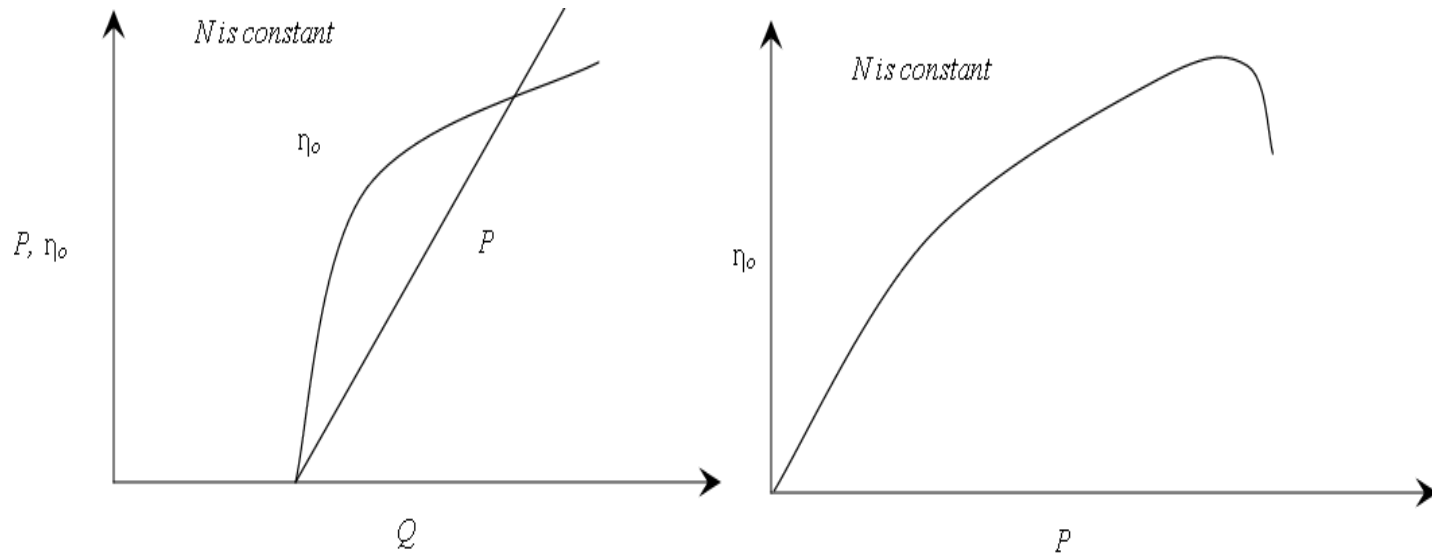

Operating Characteristic curves of a turbine

Constant efficiency curves or Muschel curves

Constant efficiency curves:

These curves are plotted from data which can be obtained from the constant head and constant speed curves. The object of obtaining this curve is to determine the zone of constant efficiency so that we can always run the turbine with maximum efficiency.

This curve also gives a good idea about the performance of the turbine at various efficiencies.

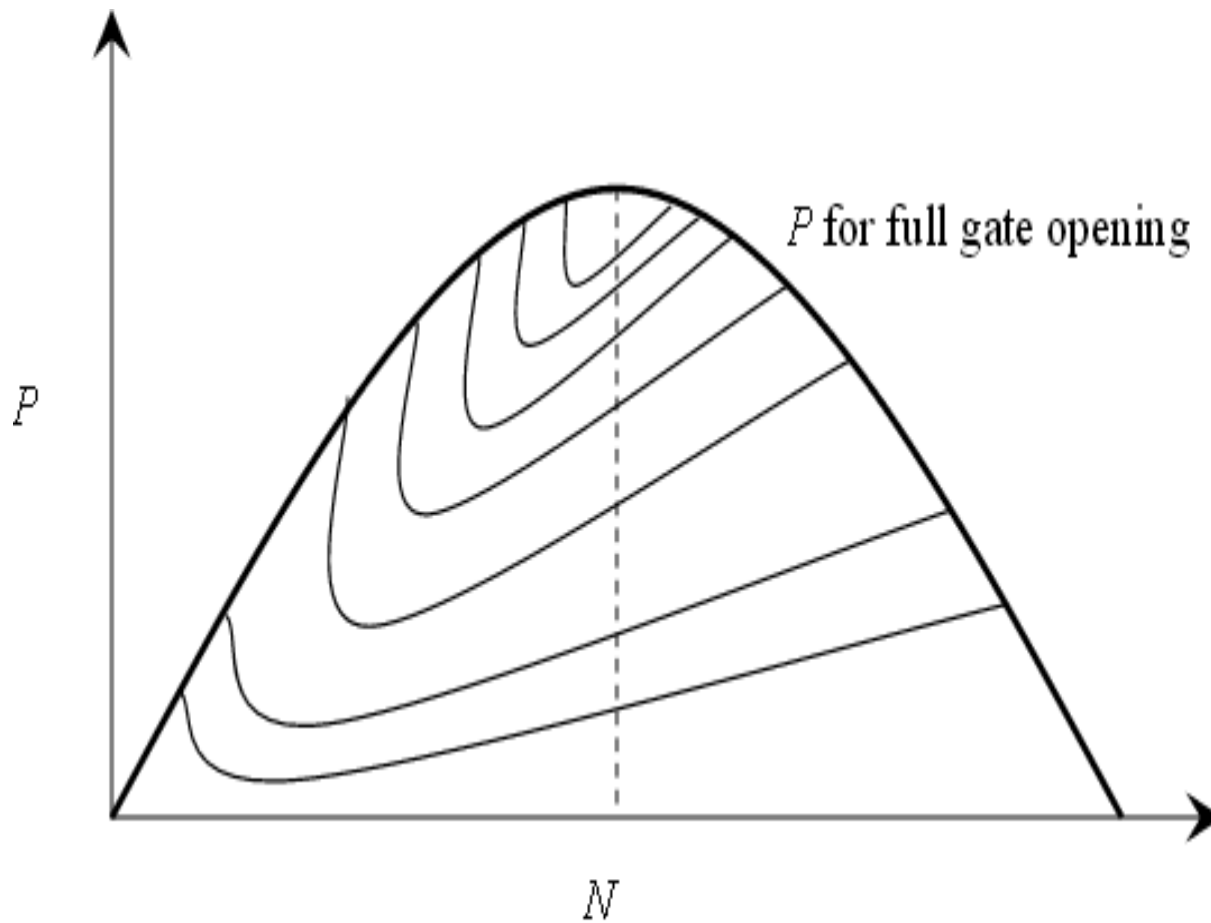

Constant Efficiency curves for Reaction turbine

Similitude of Turbines

Dimensionless Numbers:

$$\frac{Q}{ND^3}, \frac{gH}{N^2 D^2}, \frac{P}{\rho N^3 D^5}$$

Where

Q = Discharge

N = Speed of Wheel

D = Dia. of Wheel

H = Head

P = Shaft Power

Similitude of Turbines - Problems

Problems:

1. A hydraulic turbine develops 120 KW under a head of 10 m at a speed of 1200 rpm and gives an efficiency of 92%. Find the water consumption and the specific speed. If a model of scale 1: 30 is constructed to operate under a head of 8m what must be its speed, power and water consumption to run under the conditions similar to prototype.
2. A model turbine 1m in diameter acting under a head of 2m runs at 150 rpm. Estimate the scale ratio if the prototype develops 20 KW under a head of 225 m with a specific speed of 100.

Cavitations

If the pressure of a liquid in course of its flow becomes equal to its vapour pressure at the existing temperature, then the liquid starts boiling and the pockets of vapour are formed which create vapour locks to the flow and the flow is stopped. The phenomenon is known as **cavitation**.

To avoid cavitation, the minimum pressure in the passage of a liquid flow, should always be more than the vapour pressure of the liquid at the working temperature. In a reaction turbine, the point of minimum pressure is usually at the outlet end of the runner blades, i.e., at the inlet to the draft tube.

The Francis turbine are used in places like:-

SR NO .	PLACES	POWER GENERATION [MW]
1	Koyna IV (India)	250
2	Turkwell (Kenya)	53
3	Karun (Iran)	250
4	Three Gorges (China)	765

DIFFERENCE BETWEEN PELTON, KAPLAN, FRANCIS

PARAMETERS	PELTON TURBINE	KAPLAN TURBINE	FRANCIS TURBINE
TYPE OF TURBINE	IMPULSE TYPE	PROPELLER TYPE	INWARD FLOW REACTION TYPE
POWER GENRATION [MW]	400	200	800
SPEED RATE[rpm]	65 - 800	70-429	75 - 1000
EFFICIENCY[%]	85	80	90

References

- **A Textbook of Fluid Mechanics and Hydraulic Machines**

Dr. R. K. Bansal, Laxmi Publications

- **NPTEL VIDEO LECTURES**